



微光互联
二维码扫描专家



M300

User Manual



Fast recognition



Various output interface



Suitable for access control industry



Beijing Vguang Internet Technology Co., Ltd

Disclaimer

Before using the product, please read all the contents in this Product Manual carefully to ensure the safe and effective use of the product. Do not disassemble the product or tear up the seal on the device by yourself, or Beijing Vguang Internet Technology Co., Ltd. will not be responsible for the warranty or replacement of the product.

The pictures in this manual are for reference only. If any individual pictures do not match the actual product, the actual product shall prevail. For the upgrade and update of this product, Beijing Vguang Internet Technology Co., Ltd. reserves the right to modify the document at any time without notice.

Using the product is at the user's own risk. To the maximum extent permitted by applicable law, damages and risks arising from the use or inability to use this product, including but not limited to direct or indirect personal damage, loss of commercial profits, Beijing vguang Internet Technology Co., Ltd. will not bear any responsibility for trade interruption, loss of business information or any other economic loss.

All rights of interpretation and modification of this manual belong to Beijing Vguang Internet Technology Co., Ltd.

Edit history

Change date	Version	Description	Responsible
2020.11.2	V1.0	Initial version	Guohua Lau

Catalog

Disclaimer.....	2
1. Preface.....	5
1.1. Product introduction.....	5
1.2. Product feature	5
2. Product appearance	6
2.1.1. overall introduction	6
2.1.2. product size.....	7
3. Parameters.....	8
3.1. General parameter	8
3.2. Reading parameters	9
3.3. Electric parameters	10
3.4. Working environment.....	10
4. Interface definition	11
5. Device configuration.....	12
6. Mounting method.....	15
7. Attention	16
8. Contact info.....	17

1. Preface

Thank you for using the M300 scanning equipment provided by Vguang. Reading this document carefully can help you understand the functions and features of this device, and quickly master the use and installation of the device.

1.1. Product introduction

The M300 QR code reader was a specially designed embedded type device, which has various output interface, including USB, RS232, RS485, TTL, Wiegand, suitable for access control, turnstiles.

1.2. Product feature

- 1, Scan code& swipe card all in one.
- 2, Fast recognition speed, high accuracy, 0.1 second the fastest.
- 3, Easy to operate, humanized configuration tool, more convenient to config the reader.

2. Product appearance

2.1.1. OVERALL INTRODUCTION

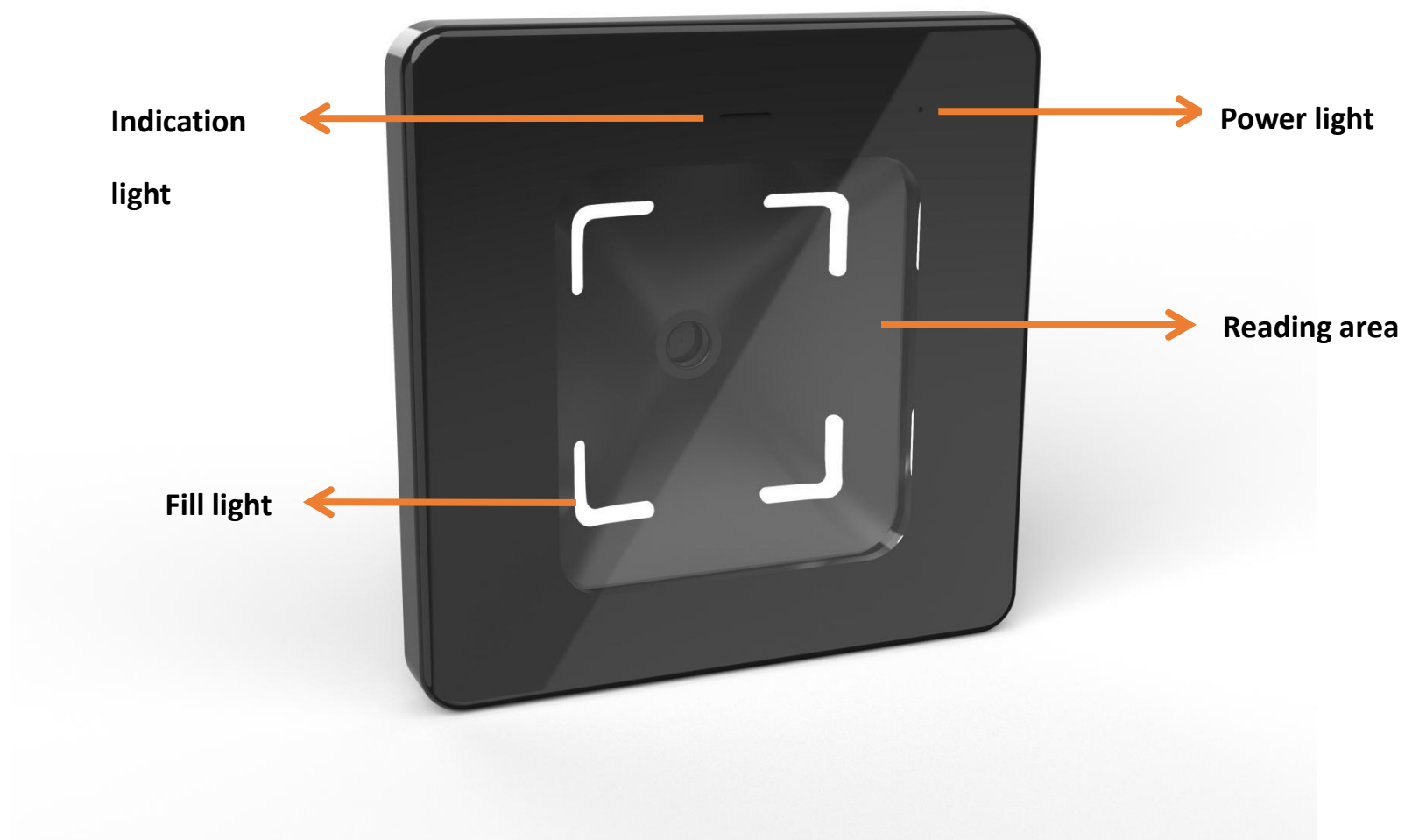

2.1.2. PRODUCT SIZE

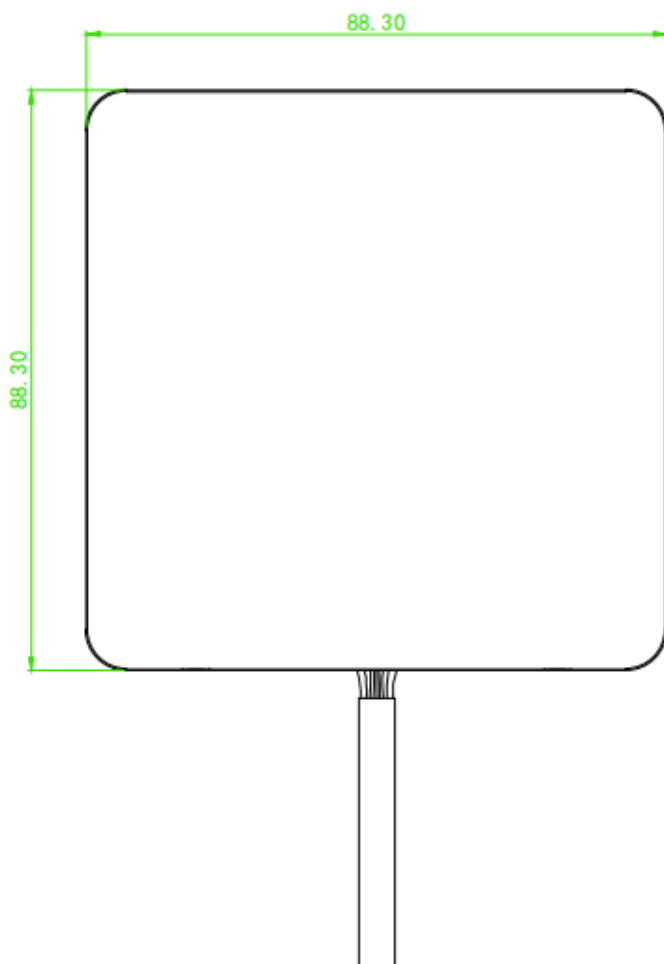

Front view

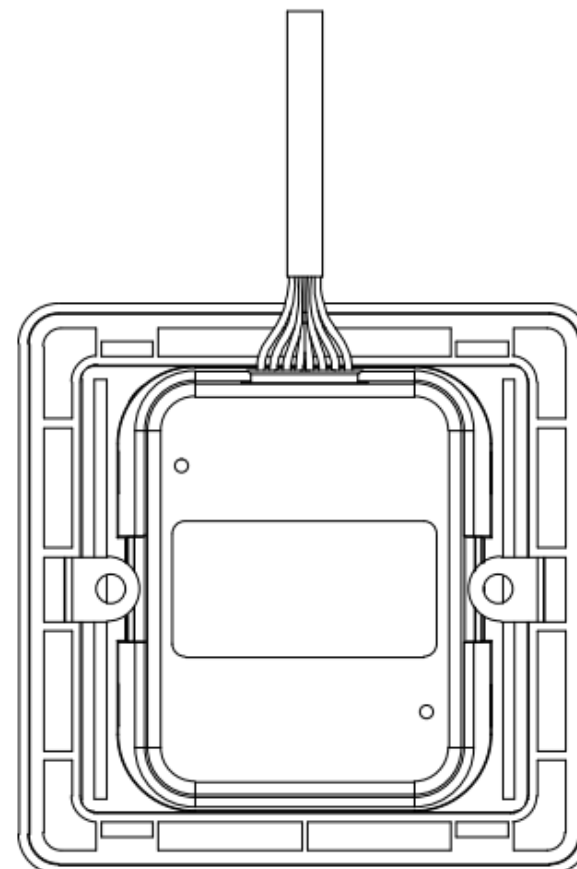

Bottom view

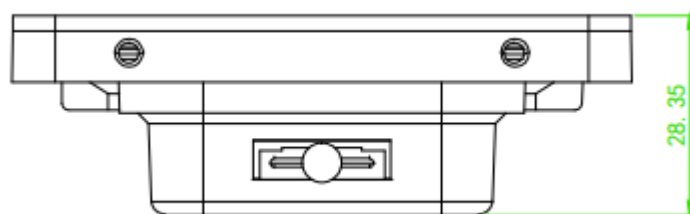

Side view

3. Parameters

3.1. General parameter

General parameter	
Output interface	USB, RS232, RS485, TTL, wiegand
Indicating method	Red, green white light indicator Beeper
Imaging sensor	300,000 pixel CMOS sensor
Max resolution	640*480
Mounting method	embedded mounting
Size	88.30mm*88.30mm*28.35mm
Reading window size	56mm*51mm

3.2. Reading parameters

QR code recognition parameter	
Symbologies	QR、PDF417、CODE39、CODE93、CODE128、ISBN10、ITF、EAN13、DATABAR、aztec, etc
Supported decoding	Both Mobile QR code and printed QR code
DOF	0mm~62.4mm(QRCODE 15mil)
Reading accuracy	≥8mil
Reading speed	70ms per time(average), support reading continuously
Reading direction	tilt±56.3° rotation±360° deflection±55.7° (15milQR)
FOV	Horizontal Field 72.1° Vertical field 56.6° filed angle 84.3° (15milQR)
RFID reading parameter	
Supported cards	ISO 14443A, ISO 14443B protocol cards
Reading method	Read UID, M1 card sector
Working frequency	13.56MHz
Distance	< 5cm

3.3. Electric parameters

The power input can be provided only when the device is connected properly. If the device is plugged or unplugged while the cable is live (hot plugging), its electronic components will be damaged. Make sure that the power is turned off when plugging and unplugging the cable. Poor power supply, too short interval power off and on operation may cause the device cannot work in a stable and normal status. It is necessary to keep the power input stable. After turning off the power input, it need to takes more than 2 seconds to turn on the power input again.

Electric parameter	
Working voltage	DC 5V-24V
Working current	200mA (5V typical value)
Power consumption	1000mW (5V typical value)

3.4. Working environment

Work environment parameter	
ESD protection	±8kV (Air discharge) , ±4kV (contact discharge)
Working temp	-20°C-70°C
Storge temp	-40°C-80°C
RH	5%-95% (No condensation) (environment temperature)
Ambient light	0-100000Lux(Non direct sunlight)

4. Interface definition

Pin#	Definition	Description
Pin 1	TTL_RX	TTL receiving end
	D0	Wiegand 0
Pin 2	TTL_TX	TTL sending end
	D1	Wiegand 1
Pin 3	GND	Ground
Pin 4	VCC	Power source
Pin 5	232_RX	232 receiving end
	485A	485 PIN
Pin 6	232_TX	232 sending end
	485B	485 PIN
Pin 7	DM	USB_data-
Pin 8	DP	USB_data+

5. Device configuration

Use the Vguang config tool to configure the device.



5.1 config tool

Config the device as the step shows, the example are showing 485 version reader.

Step 1, select the model number M300.

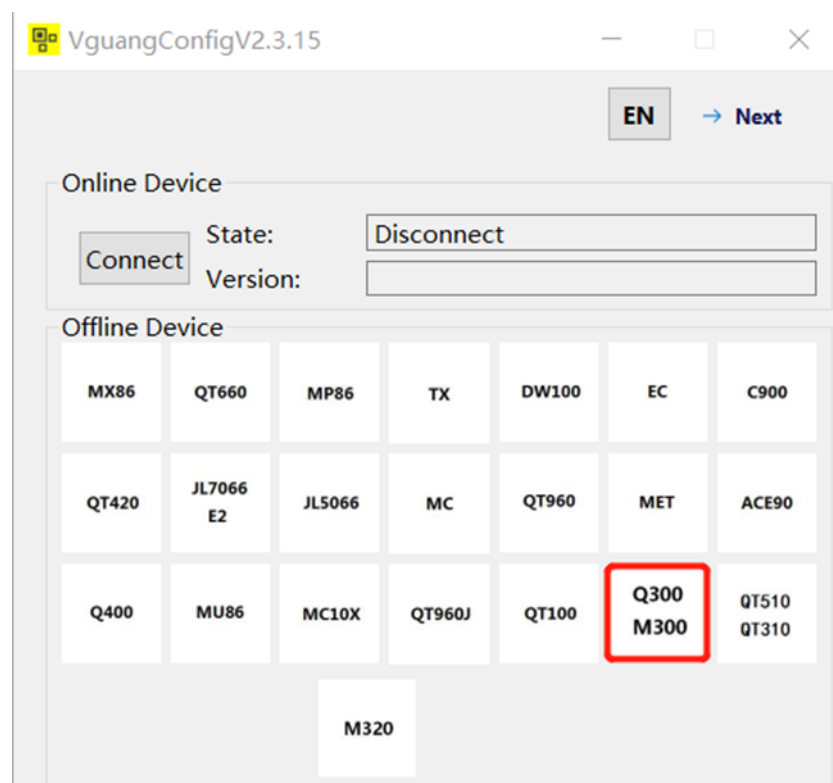

Step 2, select the output interface, and config the corresponding serial parameters.

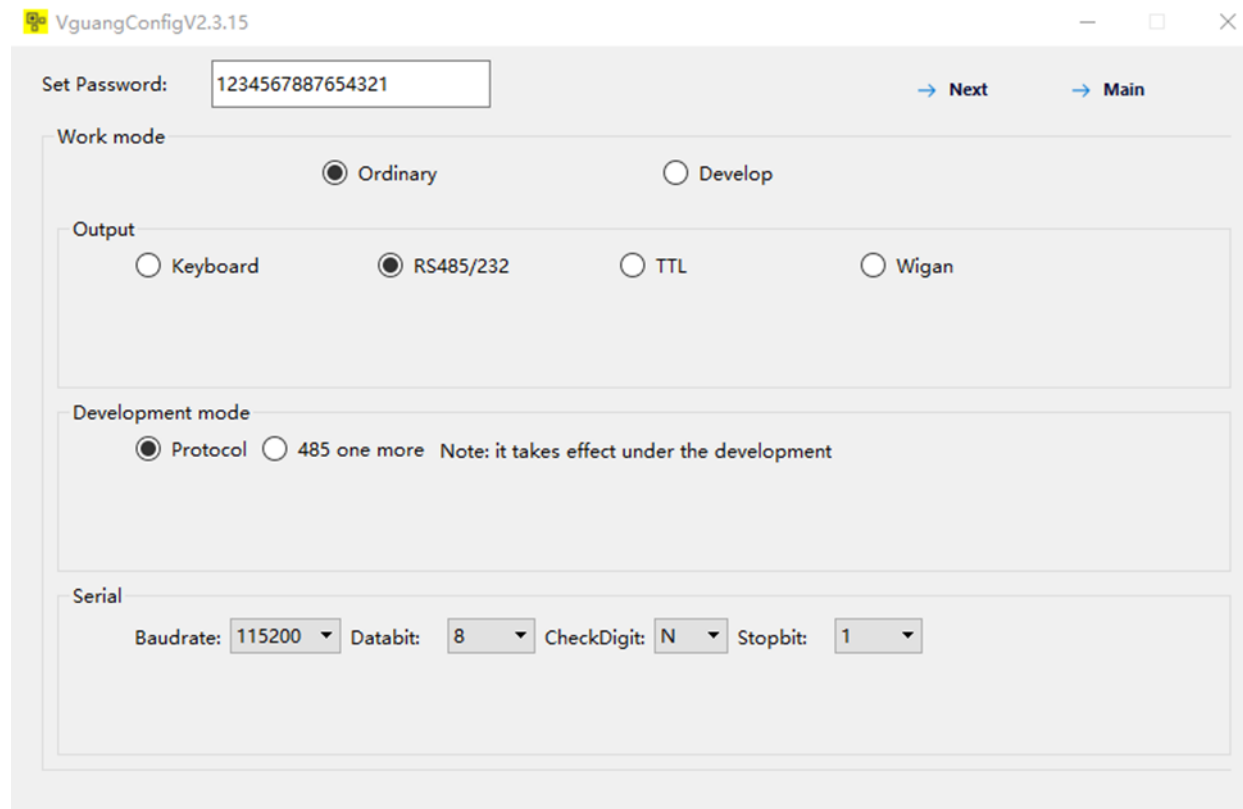

Step 3, config as your needs

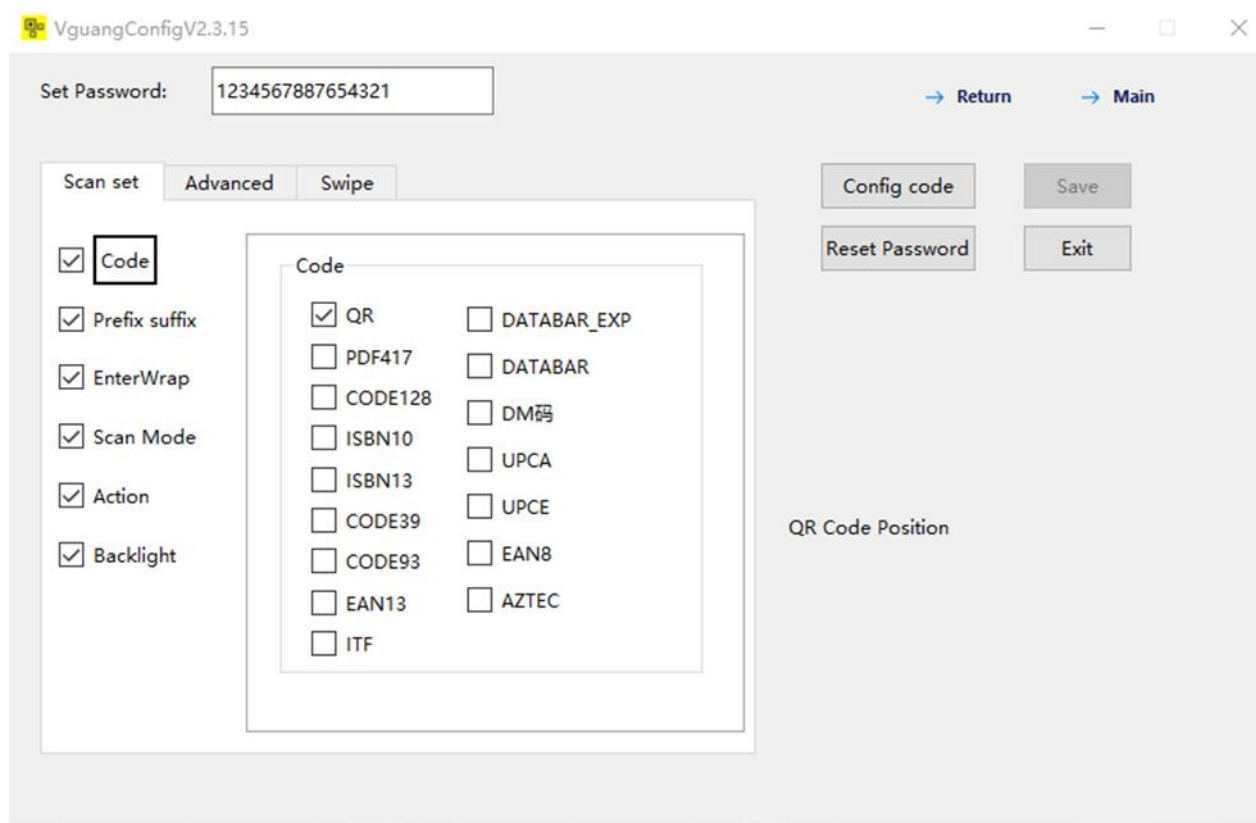

Step 4, after config as your needs, click "config code"

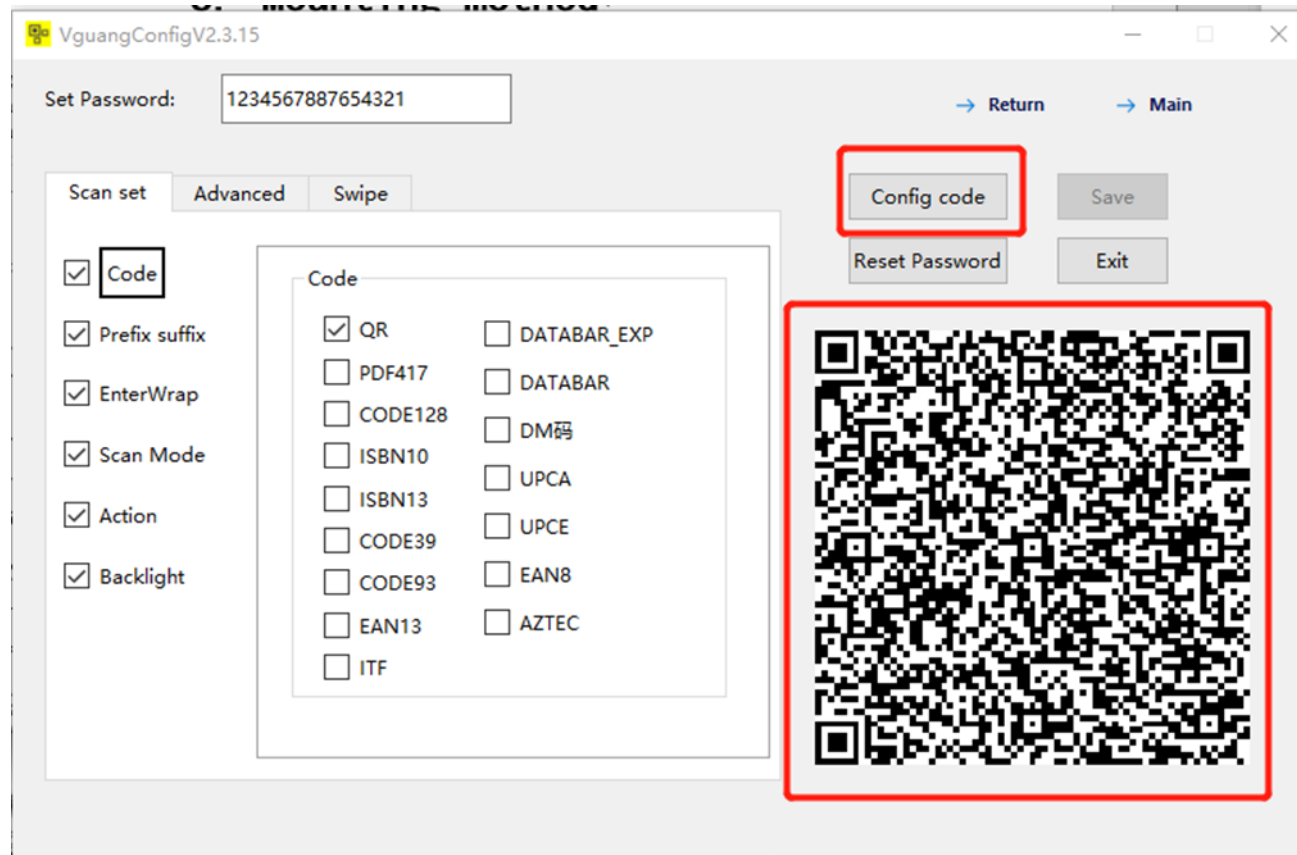

Step 5, use the scanner to scan the configurations QR code generated by the tool, then restart the reader to finish the new configurations



For more details about configurations, please refer to the "Vguang configuration tool user manual" .

6. Mounting method

The product using CMOS image sensor, the recognition window should avoid direct sun or other strong light source when install the scanner. The strong light source will cause the contrast in the image too big to decoding, the long term exposure will damage the sensor and cause the device failure.

The recognition window are using tempered glass, which has good transmission of the light, and also a good pressure resistance, but still need to avoid scratching the glass by some hard object, it will affect the QR code recognition performance.

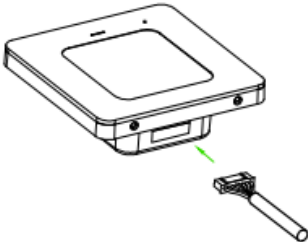
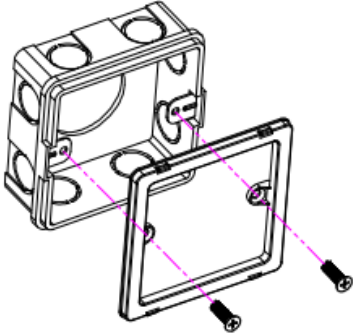
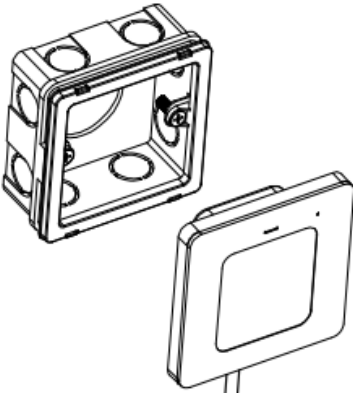
The RFID antenna was in the underside of the recognition window, there should have no metal or magnetic material within 10cm when installing the scanner, or it will affect the card reading performance

			
<p>1. plug the cable to the reader</p>	<p>2. install the holder on the 86 box, tighten with screws</p>	<p>3. install the reader on the holder, push to the end</p>	<p>4. installation completed</p>

7. Attention

1. The equipment standard is 5-24V power supply, it can get power from the access control power or power it separately. Excessive voltage may cause the device fail to work normally or even damage the device.
2. Do not disassemble the scanner without permission, otherwise the device may be damaged.
3. The installation position of the scanner should avoid direct sunlight. Otherwise, the scanning effect may be affected. The panel of the scanner must be clean, otherwise it may affect the normal image capture of the scanner. The metal around the scanner may interfere with the RFID magnetic field and affect card reading.
4. The wiring connection of the scanner must be firm. In addition, ensure the insulation between the lines to prevent the equipment from being damaged by a short circuit.



8.Contact info

Company name: Beijing Vguang Internet Technology Co., Ltd,

Address: China Meteorological Science and Technology Park, No.2, Zhenxing Road, Changping
District, Beijing, China

Hot line: 400-810-2019/ +86 18914995180